

Protocol Converter

EGW1-MB

User's Manual

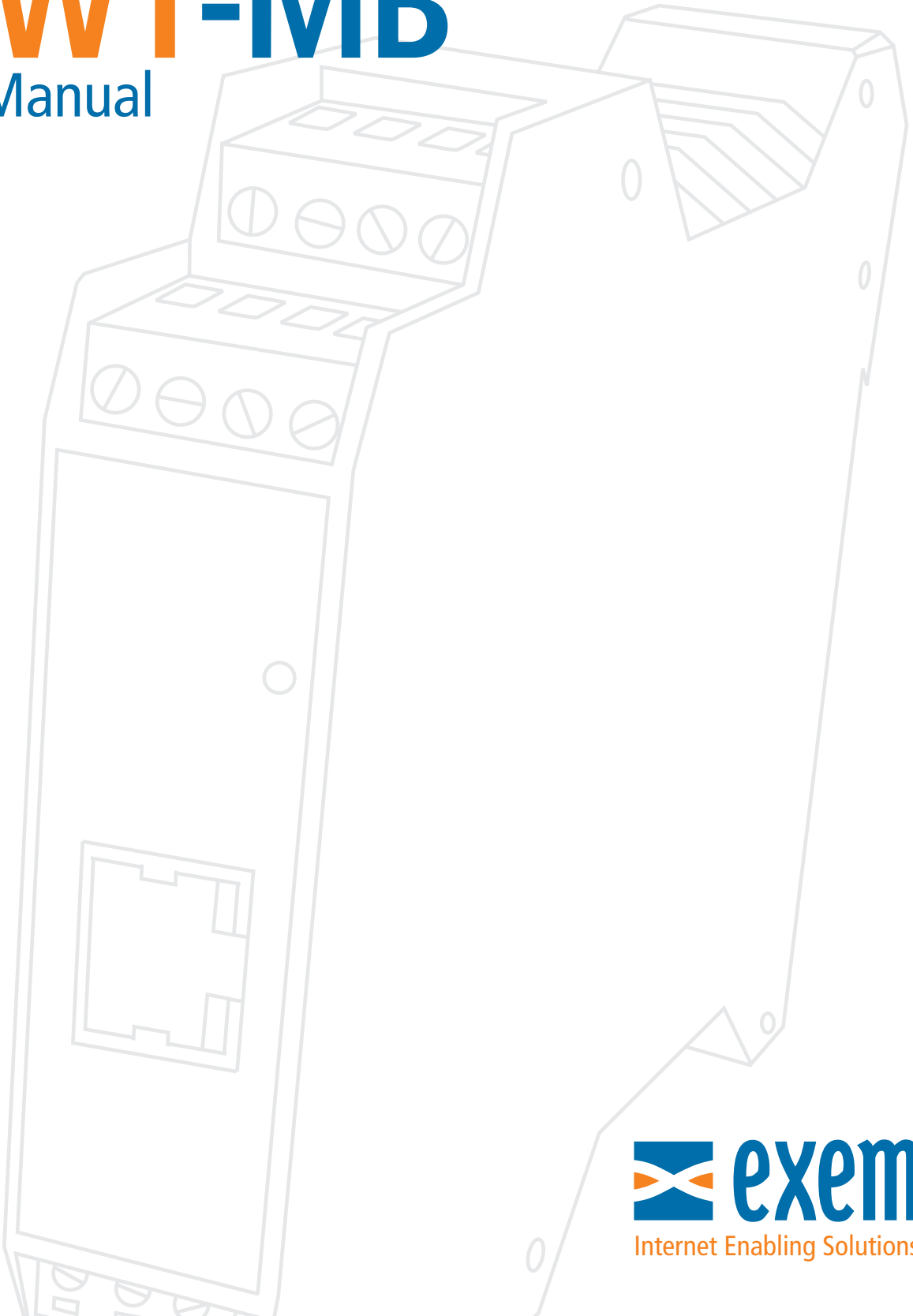

www.exemys.com

ISO 9001:2000



DEVICES APPROVED BY:



Exemys Products are in constant evolution to satisfy our customer needs.
For that reason, the specifications and capabilities are subject to change without prior notice.
Updated information can be found at www.exemys.com

Copyright © Exemys, 2006 All Rights Reserved.
Rev. 2.0.0

Table of Contents

INTRODUCTION	5
1.1 The Manual	5
1.1.1 Purpose of the manual	5
1.1.2 Conventions, terms and acronyms	5
1.2 Product Description	6
INSTALLATION	7
2.1 Power Connection	7
2.2 Inputs/Outputs	7
2.3 Serial Connection	8
2.3.1 RS-232 Connection	9
2.3.2 RS-485 and RS-422 Connection	9
2.4 Ethernet Connection	10
2.4.1 Connection through a Hub or Switch	10
2.4.2 Direct PC Connection	11
CONFIGURATION AND OPERATION	12
3.1 Getting Started	12
3.1.1 IP Address Configuration	12
3.1.2 Access to configuration Web page	13
3.1.3 TCP Configuration Command Console	14
3.1.4 Serial Configuration Command Console	14
3.1.5 Configuration of Network Basic Parameters through the console	15
3.2 Operation	16
3.2.1 Introduction	16
3.2.2 EGW1-MB General Configuration	17
3.2.3 Serial Port Configuration	19
3.2.4 Slave or Master Mode Configuration	21
3.2.5 Configuration of the Modbus/TCP List of Slaves (Master Mode)	22
3.2.6 Configuration of the Modbus/ASCII-RTU List of Slaves (Slave Mode – Only on models with more than one serial port)	23
3.2.7 Configuration of Slave Mode with multiple Masters.	24
3.2.8 Advanced Modbus Configuration Parameters	25
3.2.9 Inputs/Outputs	29
3.2.10 Statistics	30
A. APPENDIX	32
A.1. Device Locator Application	32
A.2. Indicator Leds Codes	34

A.3. Mouting	34
A.4. Technical Specifications	36

Tables

Table 1 - Acronyms	5
Table 2 - Conventions	5
Table 3 - Inputs/Outputs	7
Table 4 - Serial Connection	9
Table 5 - PASSWORD command	18
Table 6 - WEBCFG command	18
Table 7 - FACTRESET command-	19
Table 8 - RESET command	19
Table 9 - Serial Port Configuration	21
Table 10 - Slave or Master Mode Configuration	22
Table 11 - SLVSET, SLVDEL and SLVLIST commands	23
Table 12 - COMSLV command	24
Table 13 -TCPEXCEP command	25
Table 14 - COMEXCEP command	26
Table 15 - MSGTOUT command	27
Table 16 - SLVADDR command	27
Table 17 - BROADADDR command	28
Table 18 - TCPBUFFER command	29
Table 19 - INACTOUT command	29
Table 20 - IOADDR command	29
Table 21 - Statistics	30
Table 22 - Indicator Leds Codes	34

Figures

Figure 1 - Example of application	6
Figure 2 - Power Input Connection Scheme	7
Figure 3 - I/O location scheme	8
Figure 4 - Jumpers	8
Figure 5 - RS-232 Connection to a PC	9
Figure 6 - RS-485 and RS-422 Network.	10
Figure 7 - UTP cable.	10
Figure 8 - UTP crossover network cable.	11
Figure 9 - Master, Slave and Slave-Multimaster modes	16
Figure 10 - Flow of messages through EGW1-MB in Master mode	22
Figure 11 - Flow of messages through EGW1-MB in Slave mode	24
Figure 12 - Exemys Device Locator	32
Figure 13 - Assembly of the device on DIN rail	35
Figure 14 - Disassembling of the device	35

Chapter 1

Introduction

1.1 The Manual

1.1.1 Purpose of the manual

The purpose of this manual is to provide instructions for the fast and simple installation and operation of EGW1-MB over you Ethernet network.

The manual starts with the product description and then provides instructions for proper installation of its hardware. Later on, it includes detailed information on EGW1-MB configuration and operation.

1.1.2 Conventions, terms and acronyms

The acronyms used in this manual are listed in the following table.

Table 1 - Acronyms

Acronym	Description
ARP	Address Resolution Protocol
bps	Bits per second
HTTP	HyperText Transfer Protocol
IP	Internet Protocol
LAN	Local Area Network
PC	Personal Computer
UDP	User Datagram Protocol
TCP	Transmission Control Protocol
DHCP	Dynamic Host Configuration Protocol
GND	Ground (Reference)

The conventions listed below are used in this manual.

Table 2 - Conventions

Convention	Description
A B C	A set of possible values for command parameters. You can type A, B or C.
n..m	A range of possible values. You can type any value in the range including n and m.
(text)	Any text, such as a server address.
aaa.bbb.ccc.ddd	An IP Address.

1.2 Product Description

EGW1-MB is a converter from Modbus/ASCII-RTU to Modbus/TCP and vice versa.

It also supplies digital outputs/inputs that can be handled independently when acting as Modbus slave.

When EGW1-MB receives a Modbus/TCP message from a remote Master, it converts that message into Modbus/ASCII-RTU. When EGW1-MB receives a Modbus ASCII/RTU messages from the local serial Master, EGW1-MB uses a list that can be configured by the user, to decide to which IP address the Modbus/TCP message will be sent.

EGW1-MB is a complete solution for the connectivity of devices with Modbus communication Protocol that supplies, as a special feature, built-in digital inputs/outputs.

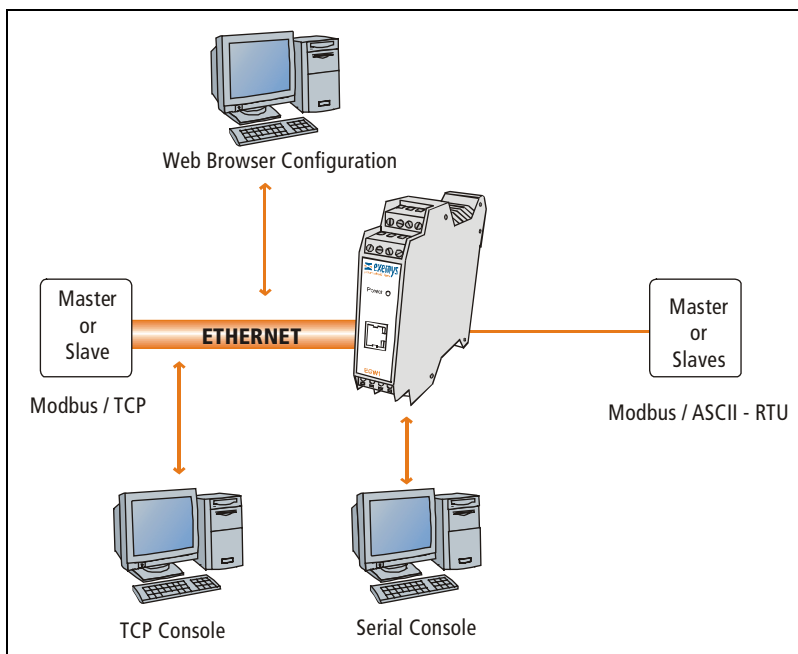

Figure 1 - Example of application

Chapter 2

Installation

2.1 Power Connection

This product must be installed and powered according to its ratings and installation instructions. The unit shall be powered from a NEC class 2 source of supply or a LPS source, having an output rated 9-26 Volts AC, 9-30 Volts DC, 200 mA min.

The installation of this product inside shall be in accordance with the NEC, specifically Article 725-54. Wiring from/to this unit is to be Class 2 wiring and shall be segregated from other wiring in the equipment as noted in the NEC.

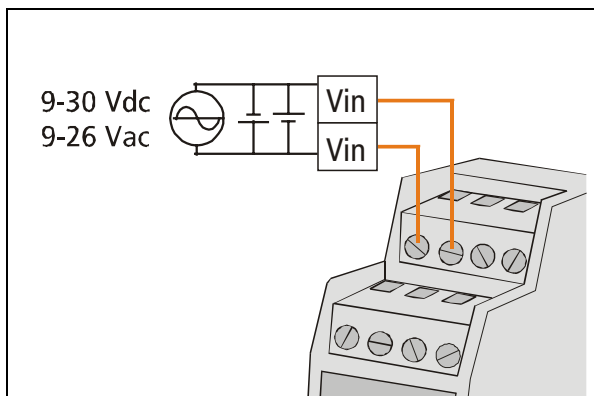

Figure 2 - Power Input Connection Scheme

2.2 Inputs/Outputs

The amount of inputs/outputs supplied by EGW1-MB is indicated in the product code.

Table 3 - Inputs/Outputs

Model	I/O	
	Inputs	Outputs
EGW1-1C4C-IA-MB	Both configurable up to 4	
EGW1-1044-IA-MB	4	4
EGW1-114C-IA-MB	Both configurable up to 4	
EGW1-224C-IA-MB	Both configurable up to 4	

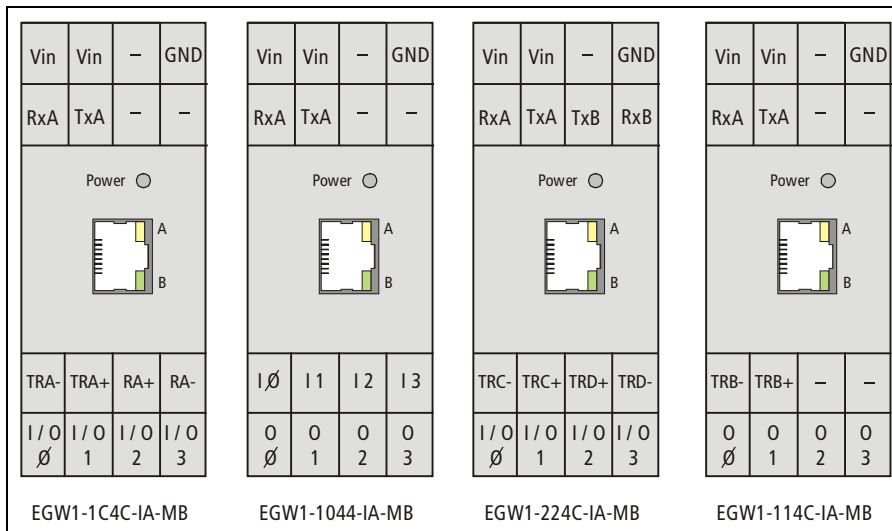

Figure 3 - I/O location scheme

Figure 4 shows inputs/outputs location in the EGW1-MB connector. Inputs/outputs are numbered starting at 0. Consequently, the first input will be I0 and, accordingly, the first output will be O0.

In models EGW1-XX4C-IA-MB I/O terminals may be configured as Inputs or Outputs depending the needs. This configuration is done in a hardwired manner changing the jumpers accordingly. In figure 5 is shown the jumpers detail for the 4 terminals. To access this jumpers open the EGW1-MB case and pull out.

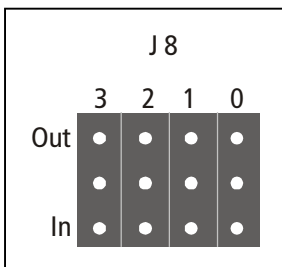

Figure 4 - Jumpers

- To make a terminal an output: short-circuit the jumper "Out" of that terminal, with the common pin (middle).
- To make a terminal an input: short-circuit the jumper "In" of that terminal, with the common pin (middle).

2.3 Serial Connection

EGW1-MB supplies serial ports that, according to the model, may only be RS-232, RS-485 or configurable by software RS-232/485/422.

Table 4 - Serial Connection

Model	Serial Port
EGW1-1C4C-IA-MB	RS-232/485/422
EGW1-1044-IA-MB	RS-232
EGW1-114C-IA-MB	1 RS-232 + 1 RS-485
EGW1-224C-IA-MB	2 RS-232 + 2 RS-485

Serial Port connection is shown in figure 4.

2.3.1 RS-232 Connection

COM A is always found in all the EGW1-MB models. A cable can be used to connect RS-232 serial ports to a PC's serial port, as can be observed in figure 6.

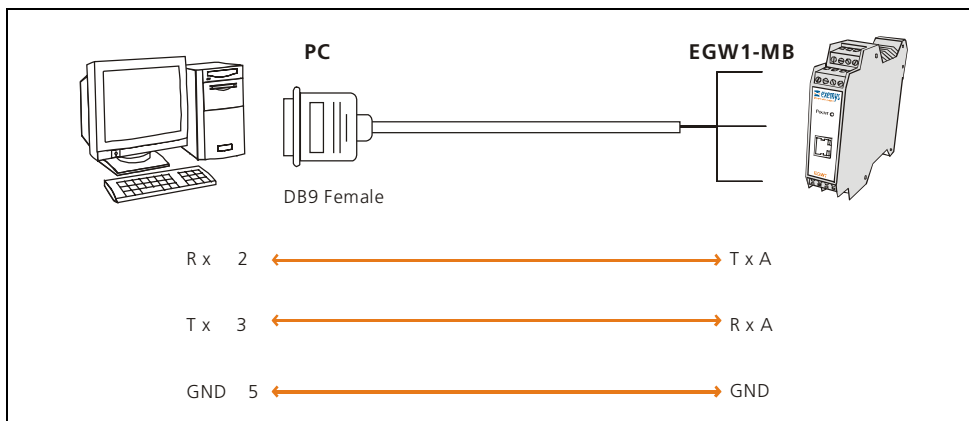

Figure 5 - RS-232 Connection to a PC

2.3.2 RS-485 and RS-422 Connection

RS-485/422 ports can be connected to a RS-485/422 network when properly configured, as shown in figure 6.

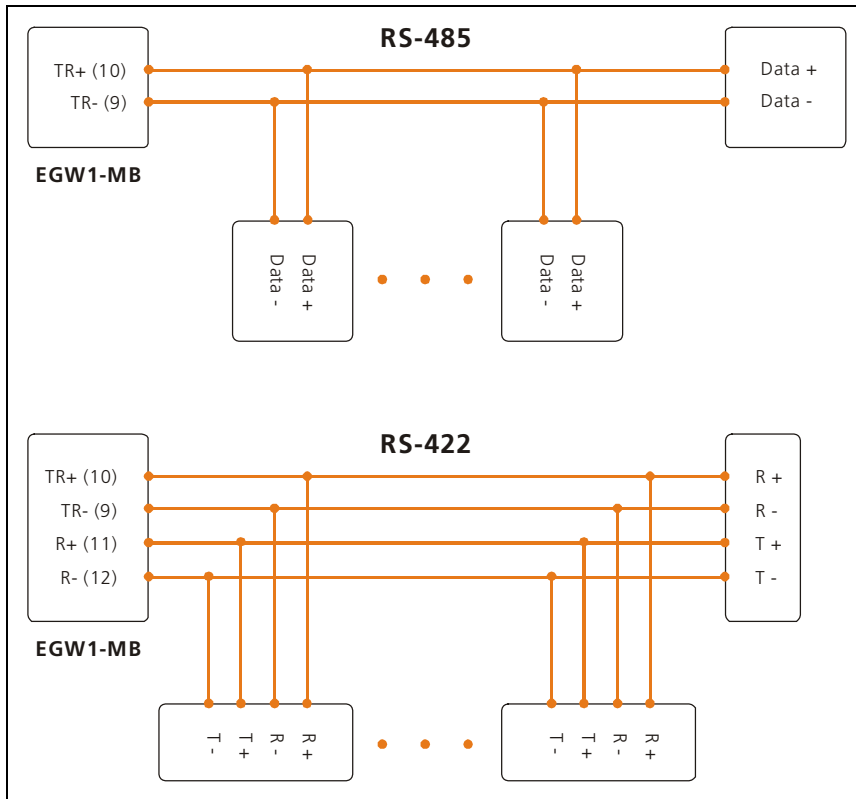

Figure 6 - RS-485 and RS-422 Network.

2.4 Ethernet Connection

2.4.1 Connection through a Hub or Switch

A UTP network cable is used to connect EGW1-MB to the Ethernet through a Hub or Switch.

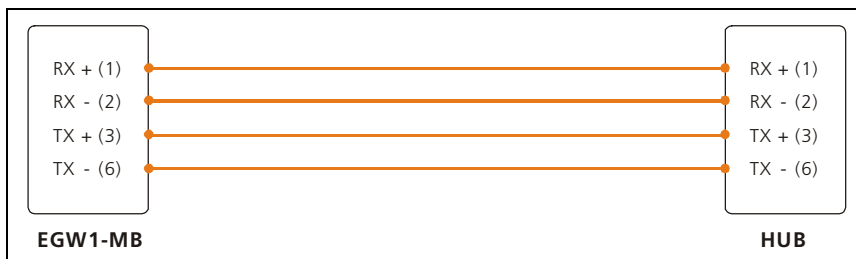

Figure 7 - UTP cable.

2.4.2 Direct PC Connection

EGW1-MB can be connected directly to a PC, without the need for a LAN. A UTP crossover network cable can be used for this connection.

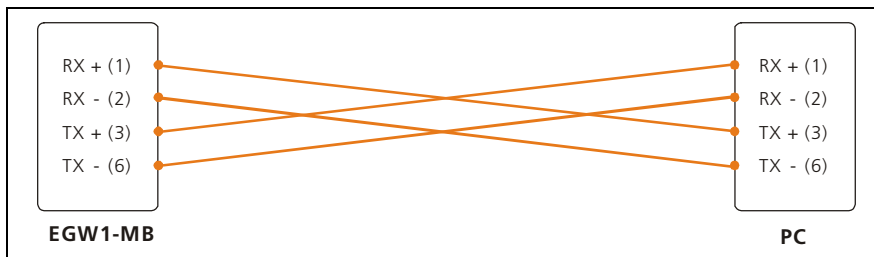

Figure 8 - UTP crossover network cable.

Chapter 3

Configuration and Operation

3.1 Getting Started

The first step consists in obtaining an IP address for EGW1-MB , by any of the following means:

- Using the Device Locator application program (most recommended method).
- Forcing an IP address entry to the ARP table.
- Locally, by accessing the command console provided by EGW1-MB , at the serial connection.

Once EGW1-MB has an IP address, the rest of the parameters can be configured:

- By accessing the configuration web page of the equipment (most recommended method).
- Using the TCP command console.
- Locally, by accessing the command console provided by EGW1-MB , at the serial connection.

All configuration parameters are permanently stored in the memory and will be maintained even in the event the equipment shuts down. Configuration parameters may be modified at any time using any of the methods mentioned above.

3.1.1 IP Address Configuration

EGW1-MB default configuration is IP 0.0.0.0, so when turned on, it will search for a DHCP server. EGW1-MB tries to negotiate an IP address with the DHCP server for a maximum period of 10 seconds. If the DHCP server fails to answer in that period, EGW1-MB will show an error code by means of its indicator LEDs (see annex) and will try to establish connection with the DHCP server 60 seconds later. This process will be repeated indefinitely until a DHCP server assigns an IP address to EGW1-MB or until the user assigns a static IP address. During the negotiation process, EGW1-MB 's yellow LED is steady on.

In the event it is decided that EGW1-MB should have a static IP number (not assigned by a DHCP server), one can be assigned by means of the ARP method.

If EGW1-MB receives, within 7 seconds after being turned on, an ICMP packet through a ping, it will take the destination IP of this packet, provided it is different from that configured in EGW1-MB .

To this effect, an entry can be added to the ARP table of a PC in the network.

The Windows ARP table must have at least one IP address other than its own in order for the ARP command to work. Be sure the ARP table has at least one entry with the command:

```
arp -a
```

If the local machine is the only entry, send a ping to another device in the network. Then add the entry to the ARP table of the PC, entering the following command:

```
arp -s 192.168.0.105 00-90-C2-XX-XX-XX
```

In Unix, the command to add an entry to the ARP table is the following:

```
arp -s 192.168.0.105 00:90:C2:XX:XX:XX
```

Send a ping to the IP address you added to the ARP table on the previous step, by entering the following command:

```
ping 192.168.0.105 -t
```

The `-t` option will cause the ping to be continuously sent.

Turn EGW1-MB on. The equipment will only respond after a few seconds. Once EGW1-MB has responded to the ping, you will have access to the equipment over the network.

3.1.2 Access to configuration Web page

Once EGW1-MB has a valid IP address you may access the web page to configure the rest of the parameters. You must use a web navigator that allows the use of Java Scripts.

1. If your web navigator is configured to search for a Proxy server, disable that option.
2. Type the EGW1-MB IP address in the "address" field of your navigator.

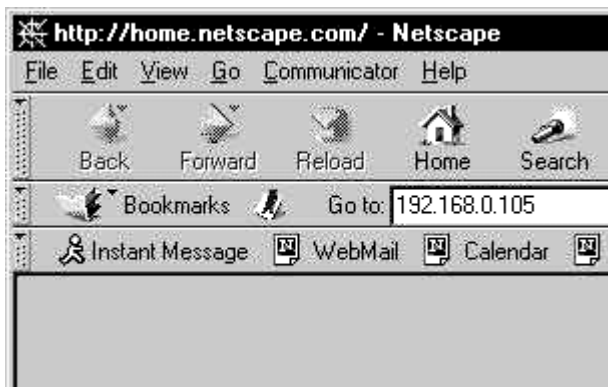

EGW1-MB will ask for the password to enter to the page. Type "admin" as user name and then the password to enter.

3. You will see the EGW1-MB configuration web page. On the left side, you will find the menu, and on the right side, you will find the configuration page.

3.1.3 TCP Configuration Command Console

EGW1-MB supplies a command console to allow configuration by TCP in the **port23**. The machine will only administer one connection in this port, thus preventing the device to be configured in simultaneous consoles.

To enter the console establish a telnet connection to port 23. In Windows, open a window of commands and type the following command:

```
telnet 192.168.0.105
```

When the connection is established, EGW1-MB will show a welcome message to the configuration command console.

```
EGW1-MB Modbus TCP to Modbus RTU Converter (V1.3)
```

```
-----  
Password:
```

EGW1-MB will ask for a "Password":

You will then have three opportunities to enter your password. After that, the console will be blocked for 5 seconds before allowing you to re-enter your password.

3.1.4 Serial Configuration Command Console

Locally, you can access the serial port command console by connecting COM A to a RS-232 port of a PC. To such effect, you must have a serial terminal program (Windows HyperTerminal or the like).

The communications program must be set as follows: **9600 bps, Parity: None, Data bits: 8, Stop bits: 1, and flow control: none (9600,N,8,1)**.

You can enter the configuration mode through the serial port:

- Connect EGW1-MB to a PC and configure the terminal emulation program to 9600,N,8,1.
- Turn on EGW1-MB . During the first 7 seconds EGW1-MB will wait for the **CFG** command.
- Type **CFG** and press ENTER. The EGW1-MB will display a welcome message to the configuration command console.

```
EGW1-MB Modbus TCP to Modbus RTU Converter (V1.3)
```

```
-----  
>
```

3.1.5 Configuration of Network Basic Parameters through the console

Once you access the console, you can change the network configuration parameters with the following commands: **IP**, **NETMASK**, and **GATEWAY**. If you want to change the EGW1-MB IP address, Netmask and / or Gateway, you can enter the commands to modify these parameters. But then you must enter the **END** command so the changes take effect. When the **END** command is executed, EGW1-MB will detect that any of these three basic parameters has been changed and the system will be restarted. If the console is run from a Telnet session, the communication with the equipment will be interrupted. You must reopen the TCP session using the new IP address.

- To change the IP address, enter the following command:

```
>ip:192.168.0.110
Ok, IP Address      192.168.0.110
NOTICE, This parameter will be accepted upon execution of the END command.
At that moment, communication with the equipment will be interrupted.
If you are not sure, close communication without typing the END command.
>_
```

- To change the **netmask**, enter the following command:

```
>netmask:255.255.255.0
Ok, Netmask        255.255.255.0
NOTICE, This parameter will be accepted upon execution of the END command.
At that moment, communication with the equipment will be interrupted.
If you are not sure, close communication without typing the END command.
>_
```

- You can change the Gateway using the **gateway** command. Enter the following command:

```
>gateway:192.168.0.200
Ok, Gateway        192.168.0.200
NOTICE, This parameter will be accepted upon execution of the END command.
At that moment, communication with the equipment will be interrupted.
If you are not sure, close communication without typing the END command.
>_
```

- Enter the **END** command for EGW1-MB to accept the network parameter changes. You will lose communication with the equipment if the commands were entered from the TCP console.

3.2 Operation

3.2.1 Introduction

EGW1-MB translates the Modbus/TCP messages received from remote masters into Modbus/ASCII-RTU messages to serial local slaves (Slave Mode), or translates the Modbus/ASCII-RTU messages from serial local master into Modbus/TCP to remote slaves (Master Mode). Slave mode can handle up to 8 Modbus/TCP masters, which messages will be translated into Modbus/ASCII-RTU to local serial slaves (Slave Mode with Multiple Masters).

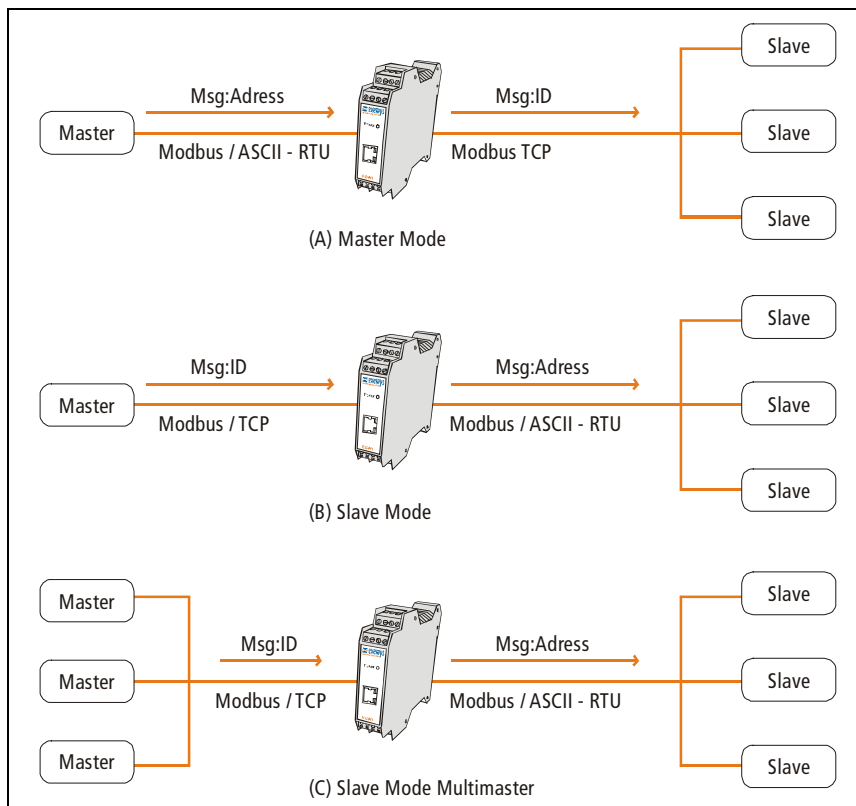

Figure 9 - Master, Slave and Slave-Multimaster modes

3.2.1.1 Slave Mode.

EGW1-MB Slave Mode translates the Modbus/TCP messages from remote masters into serial local slaves Modbus/ASCII or Modbus/RTU.

In general, the Unit ID of the Modbus/TCP messages will be directly translated to the addresses of the serial local slaves, but a fixed Address may also be configured. In models with more than one serial port EGW1-MB will search the Unit ID in a list to decide which serial port to use with that message.

3.2.1.2 Master Mode.

EGW1-MB Master mode translates the messages from serial local master Modbus/ASCII or Modbus/RTU to remote Modbus/TCP slaves.

A configurable list allows EGW1-MB to obtain the remote slave's IP from the Modbus/ASCII-RTU address of the message. The address is translated by the Unit ID of the Modbus/TCP messages to remote slaves. **The serial master can only be attached to COM A.**

3.2.1.3 Slave Mode with Multiple Masters.

EGW1-MB allows you to handle up to 8 Modbus/TCP remote masters while it translates their messages to local Modbus/ASCII or Modbus/RTU slaves in the serial connection RS-232/485/422. If EGW1-MB receives interrogations from one master before an answer is given to another one, EGW1-MB will save the interrogations, to interrogate one slave at a time. Translation of messages is done in the same way than in Slave Mode.

3.2.2 EGW1-MB General Configuration

In this chapter, we will focus on the general aspects of EGW1-MB configuration.

3.2.2.1 How to obtain help from the command console.

To obtain help regarding a specific command, you can type the command followed by an interrogation mark "?". The console will display a help message, the syntax and a descriptive text.

```
>port?
PORTx:...      Listen Port (1..65535)
```

```
>_
```

By executing the **HELP** command you will be able to read a complete list of all available commands with their syntax and a descriptive text.

3.2.2.2 Access Key to Configuration

Both the TCP configuration console and the web page are protected by an access key. The device administrator may assign an access key for these resources, thus supplying safe access to EGW1-MB configuration.

To change the access key through the Web page:

- Select "Advanced" from the menu, you will see the advanced configuration page.
- Enter the Password in the "New Password" box, and type it again to confirm.
- Click on the "Change Password" button, so the EGW1-MB may take the changes.

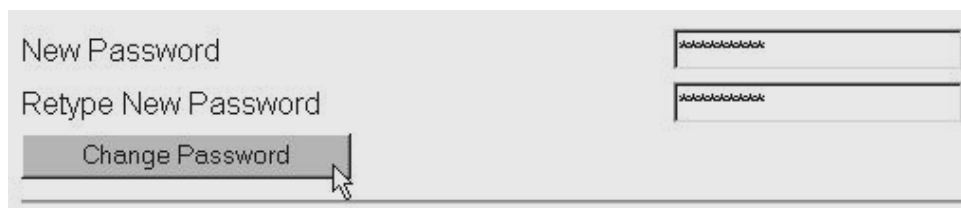

The administrator may change the access key for the command console (both through TCP or, locally, through the serial port) by executing the **PASSWORD** command.

Table 5 - PASSWORD command

Command	Description
PASSWORD: (password)	Changes the access key for remote configuration (TCP command console or configuration Web Page). The key word must not have more than 10 characters

3.2.2.3 Enabling and Disabling Web Configuration

The administrator may enable or disable EGW1-MB configuration through the Web page. Once disabled, the administrator will only be able to access the configuration remotely through the TCP command console or, locally, by the serial command console. In both cases, the administrator will be able to re-enable Web Configuration.

To enable or disable EGW1-MB Web Configuration through the Web page:

- Select "Network" from the menu, you will see the Network configuration page.
- Select the Web Configuration Enabling from the combo box.
- Click on the "Send" button, so the EGW1-MB may take the changes.

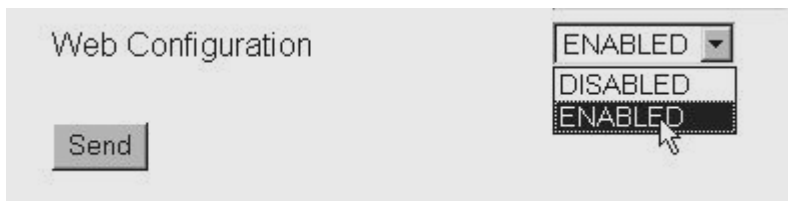

From the command console (via TCP or serial), you may enable or disable the option of configuration through the web page by executing the **WEBCFG** command:

Table 6 - WEBCFG command

Command	Description
WEBCFG: (E D)	Enables or disables configuration through the Web page. E = Enables D = Disables

3.2.2.4 How to reset to manufacturer's configuration

At any time, EGW1-MB administrator may reset the original manufacturer's configuration. This option may be executed both through the Web page and through the command console.

To reset the original manufacturer's configuration from the EGW1-MB Web page:

- Select "Advanced" from the menu, you will see the advanced configuration page.
- Click on the "Set EGW1-MB to Factory Defaults" button. A message will appear asking you to confirm the action.

- Select "Yes" if you want to reset EGW1-MB to Factory Default Configuration.

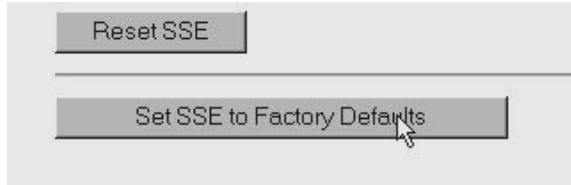

From the command control you may execute the **FACTRESET** command to reset the original configuration. This command must be entered twice for EGW1-MB to reset its predetermined configuration.

Table 7 - FACTRESET command-

Command	Description
FACTRESET	Resets the original manufacturer's configuration. This command must be entered twice for the EGW1-MB to reset the manufacturer's configuration.

3.2.2.5 EGW1-MB Reset

If necessary, EGW1-MB may be reset at any time.

To reset EGW1-MB through the Web page:

- Select "Advanced" from the menu, you will see the advanced configuration page.
- Click on the "Reset EGW1-MB " button. A message will appear asking you to confirm the action.
- Select "Yes" if you want to reset EGW1-MB.

From the command console, you may reset EGW1-MB by executing the **RESET** command. This command must be executed twice for the EGW1-MB to reset.

Table 8 - RESET command

Command	Description
RESET	Resets EGW1-MB . This command must be executed twice for EGW1-MB to reset.

3.2.3 Serial Port Configuration

Configuration parameters are:

- **Baud Rate:** Serial Port rate of transference by bits per second. Possible values are: 2400, 4800, 9600, 14400, 19200, 28800, 38400, 57600 and 115200
- **Parity:** Type of parity. Possible Values are: NONE (without parity), EVEN (Even parity) and ODD (Odd parity).

- **Type of COM:** You may select RS-232, RS-485, or RS-422 depending on the EGW1-MB 's model.
- **Protocol or Format:** You may select Modbus/ASCII or Modbus/RTU. When you select Modbus/RTU the serial transmission pattern will be of 8 bits. If you select Modbus/ASCII, data bits will be 7.
- **Packet Timeout (only for Modbus/RTU):** Modbus/RTU packets are divided by time periods. This parameter allows to change the maximum time, to be calculated after the reception of the last byte of the packet, during which EGW1-MB will presume that such packet has not yet finished to arrive. After the lapse of the maximum time period, EGW1-MB will presume the packet has finished its arrival. The packet timeout is calculated as units of time of a byte, being the minimum of 3 bytes.

To configure these parameters through the EGW1-MB Web Page:

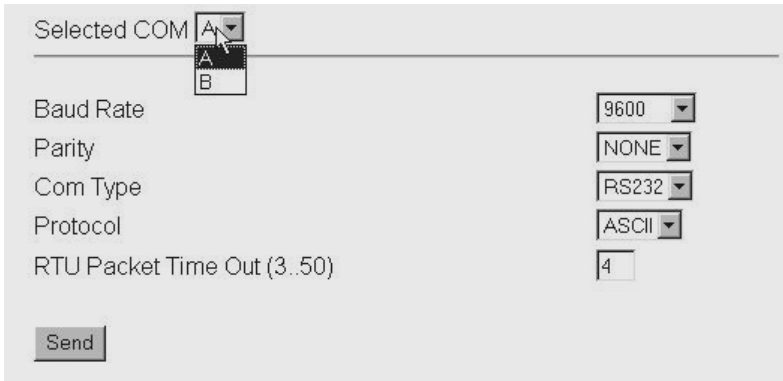

The screenshot shows a configuration form with the following fields and values:

Selected COM	A
Baud Rate	9600
Parity	NONE
Com Type	RS232
Protocol	ASCII
RTU Packet Time Out (3..50)	4

A "Send" button is located at the bottom left of the form.

- In models with more than one serial port select the COM to configure.
- Change any values as necessary. Click on the "Send" button so the EGW1-MB may take the changes

You may also configure these parameters from the configuration command console (Replace X with A,B,C or D depending on the serial port to configure)

Table 9 - Serial Port Configuration

Command	Description
BAUDx: (Baud_rate)	Configures the COM X rate of transference by bits per second. Possible values are 2400, 4800, 9600, 14400, 19200, 28800, 38400, 57600 o 115200.
PARITYx: (N E O)	Configures COM X parity N = NONE E = EVEN O = ODD
COMTYPEx: (0 1 2)	Configures type of COM X. 0 = RS-232 1 = RS-485 2 = RS-422
FORMATx: (R A)	Selects between Modbus/ASCII and Modbus/RTU in COM X. R = Modbus/RTU. A = Modbus/ASCII
PKTOUTx: (..)	Modbus/RTU Packet Timeout in COM X.

3.2.4 Slave or Master Mode Configuration

In Slave mode, you will be able to connect serial Slaves Modbus/ASCII or Modbus/RTU devices to the EGW1-MB serial ports, as, for example, a controller or a PLC.

In Master Mode, serial port COM A will receive the messages from the serial local Master Modbus/ASCII or Modbus/RTU, for example, a PC running HMI (Human-Machine-Interface)software, or a Master Mode PLC.

To do so, the following parameters must be configured:

- **COM Attached:** This parameter will be MASTER or SLAVE, depending on the device/s attached (Modbus Master or Slave).

To configure these parametes through the EGW1-MB Web page:

- Select "Modbus RTU/ASCII" from the menu.
- Select MASTER or SLAVE
- Click on the "Send" button so the EGW1-MB may take the changes.
-

You may also change these parameter through the configuration command console.

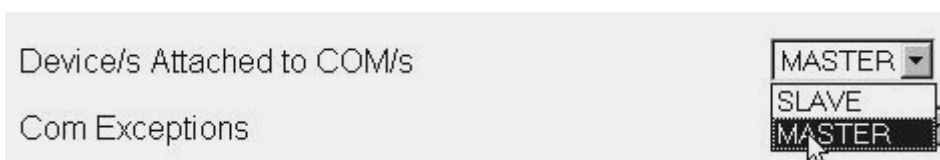

Table 10 - Slave or Master Mode Configuration

Command	Description
COMATTACHED: (S M)	Configures COM A Mode. S = Slave Mode M = Master Mode

3.2.5 Configuration of the Modbus/TCP List of Slaves (Master Mode)

In Master Mode, you must indicate the IP to which to send the Modbus/TCP interrogation related to the address of the Modbus/ASCII-RTU interrogation.

EGW1-MB allows to define a list that indicates to which IP a determined group of addresses must be linked.

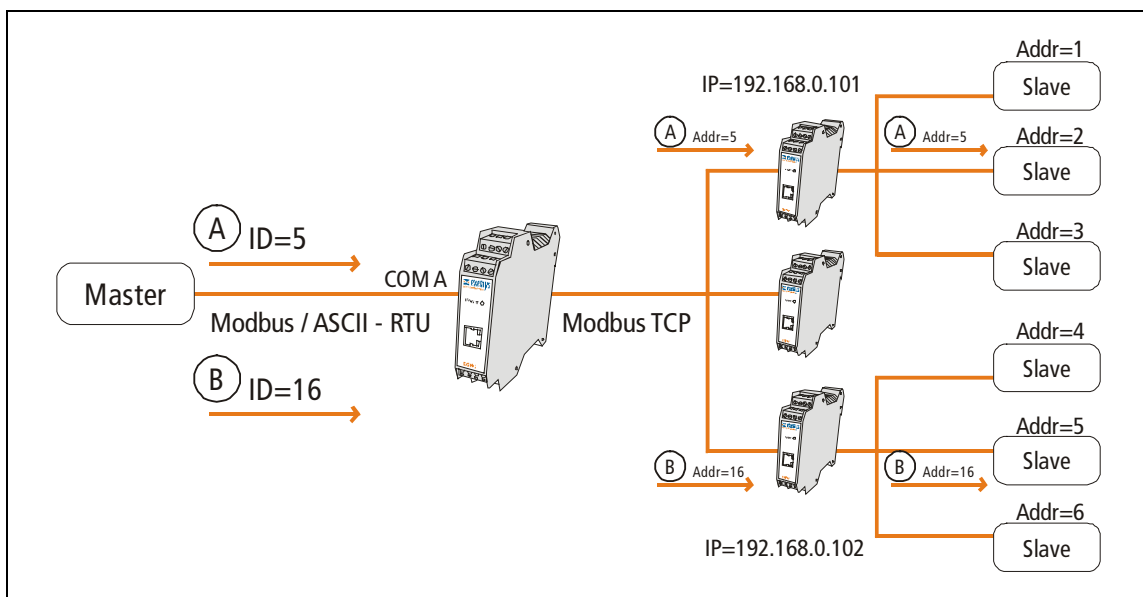

Figure 10 - Flow of messages through EGW1-MB in Master mode

Thus, EGW1-MB in Master mode searches on a configurable list the Address of the messages it receives, searches the corresponding range, and obtains the IP of the slave that will receive the message. The list has a maximum of 8 possible IP groups. An IP address corresponds to each group. The first group of slaves is identified as 'A' and the last one, as 'H'.

To configure the Modbus/TCP slaves list through the EGW1-MB Web page:

- Select. "TCP Slaves" from the menu. You will see the Slaves list
- To enable a range, check the corresponding box (A..H).
- Type the First and the Last ID for the range to be sent to the destination IP Address.
- Enter the IP Address of the Modbus/TCP Slave.
- Click on the "Send" button to make the EGW1-MB take the changes made.

The screenshot shows the Exemys web interface for configuring Modbus/TCP slaves. The sidebar on the left contains the following links: EGW1-MB, ModbusTCP to ModbusASCII/RTU Converter, Network, Modbus, Modbus TCP, Modbus RTU/ASCII, TCP Slaves, Statistics, and Advanced. The main content area displays a table with columns for Slaves, First Unit, Last Unit, and IP Address. A 'Send' button is located below the table.

Slaves	First Unit	Last Unit	IP Address
<input checked="" type="checkbox"/> A	1	9	192.168.0.100
<input checked="" type="checkbox"/> B	10	19	192.168.0.105
<input checked="" type="checkbox"/> C	20	29	192.168.0.95
<input checked="" type="checkbox"/> D	30	39	192.168.2.56
<input checked="" type="checkbox"/> E	40	49	192.168.10.30
<input type="checkbox"/> F	1	1	192.168.0.100
<input type="checkbox"/> G	1	1	192.168.0.100
<input type="checkbox"/> H	1	1	192.168.0.100

ID and IP address of EGW1-MB s of Modbus/TCP slaves may be altered through the command console by executing the **SLVSET**, **SLVDEL** and **SLVLIST** commands. The **SLVLIST** command will allow you to see the configuration of each entry on the list.

Table 11 - SLVSET, SLVDEL and SLVLIST commands

Command	Description
SLVSET: (A..H) -FID-LID-SLVIP	Changes an entry on the Modbus slaves list. (A..H) = group to be changed FID = First ID Group (1..255) LID = Last ID Group (1..255) SLVIP = Slave IP Address.
SLVDEL: (A..H)	Deletes a group from the Modbus/TCP slaves list. (A..H) = Group to be deleted
SLVLIST	Shows the Modbus/TCP slave list.

3.2.6 Configuration of the Modbus/ASCII-RTU List of Slaves (Slave Mode – Only on models with more than one serial port)

In Slave Mode, you must indicate the serial port to which to send the Modbus/ASCII-RTU interrogation related to the Unit ID of the Modbus/TCP interrogation.

EGW1-MB allows to define a list that indicates to which Serial Port a determined group of addresses must be linked.

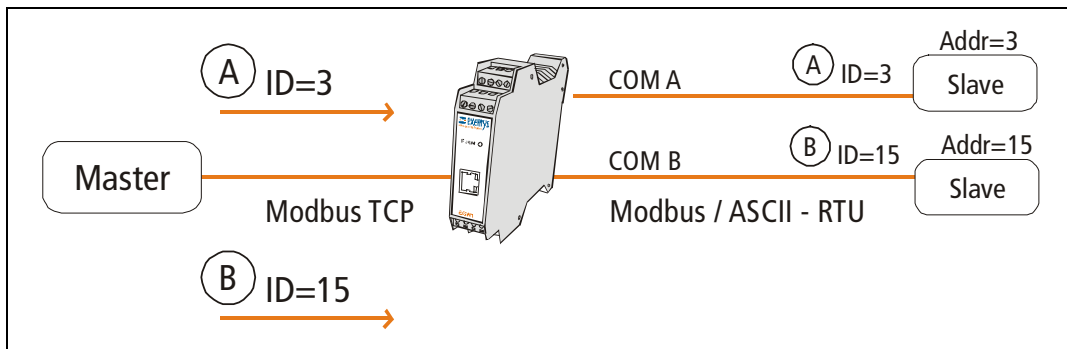
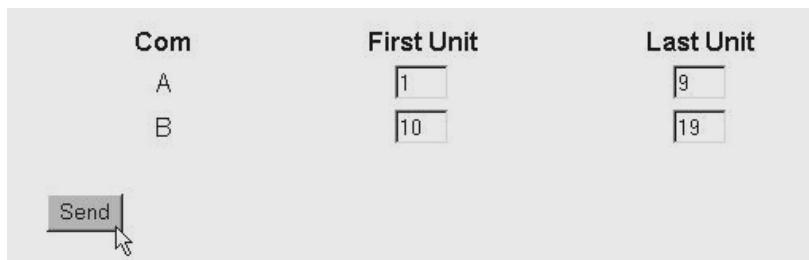

Figure 11 - Flow of messages through EGW1-MB in Slave mode

Thus, EGW1-MB in Slave mode searches on a configurable list the Unit ID of the messages it receives, searches the corresponding range, and obtains the Serial Port of the slave that will receive the message.

To configure the RTU-ASCII slaves list through the EGW1-MB Web page:

- Select. "RTU-ASCII Slaves" from the menu. You will see the Slaves list
- Type the First and the Last Unit ID for the range of each serial port.
- Click on the "Send" button to make the EGW1-MB take the changes made.



First and Last Unit ID of Modbus/ASCII-RTU slaves may be altered through the command console by executing the **COMSLV** command.

Table 12 - COMSLV command

Command	Description
COMSLVx:FID-LID	Changes an entry on the Modbus ASCII/RTU slaves list. x = A,B,C or D FID = First Unit ID (1..255) LID = Last Unit ID (1..255)

3.2.7 Configuration of Slave Mode with multiple Masters.

EGW1-MB may handle up to 8 remote Modbus/TCP masters in slave mode.

So, EGW1-MB maintains up to 8 TCP connections with the multiple masters, from which EGW1-MB will receive the messages that will be translated to the Modbus/RTU or Modbus/ASCII slaves.

If all 8 connections are covered by 8 Modbus/TCP masters and a ninth master tries to connect, EGW1-MB will automatically close the oldest connection to allow the connection to the new master.

3.2.8 Advanced Modbus Configuration Parameters

3.2.8.1 Exceptions

EGW1-MB may be configured to answer or not to answer to the master to exceptions concerning errors in the communication with the slaves. If the option is disabled, EGW1-MB will answer the errors with silence. If the option is enabled, EGW1-MB will return an exception code, as follows.

- **Slave Mode:**

In Slave Mode, you may configure the TCP option "Exception".

To do so through the configuration Web Page:

- Select "Modbus TCP" from the menu.
- Enable or Disable TCP Exceptions from the combo box
- Click on the "Send" button to make the EGW1-MB take the changes.



From the command console, you must execute the **TCPEXCEP** command.

Table 13 -TCPEXCEP command

Command	Description
TCPEXCEP: (E D)	Enables or disables exceptions in mode Slave. E = Enabled D = Disabled

In Slave Mode, EGW1-MB will send only one exception:

- **0x0A:** This exception is produced because:
 - The message has a slave address that is not configured in the slave list (only for models with more than one channel)
- **0x0B:** This exception is produced by:
 - Error in the serial parity.
 - Error in serial CRC/LRC.
 - Error in serial Frame.
 - No answer was received during the waiting period of the message (Message timeout).

- **Master Mode:**

In Master Mode, you may configure the COM Exception option.

To do so through the configuration Web Page:

- Select "Modbus RTU/ASCII" from the menu.
- Enable or Disable COM Exceptions from the combo box
- Click on the "Send" button to make the EGW1-MB take the changes.

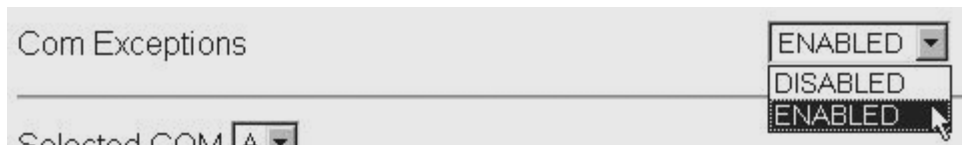

From the command console, you may execute the **COMEXCEP** command.

Table 14 - COMEXCEP command

Command	Description
COMEXCEP : (E D)	Enables or disables mode Master exceptions. E = Enabled D = Disabled

In Master Mode, EGW1-MB will send one of these exceptions:

- **0x0A:** This exception is produced because:
 - The message has a slave address that is not configured in the slave list.
 - TCP connection fails. The reasons for the failure may be temporary or due to an incorrect configuration.
- **0x0B:** This exception is produced because:
 - No answer was received during the message waiting period (Message timeout).
 - Header of the message received is invalid.
 - Connection was closed while waiting for the answer.

3.2.8.2 Message Timeout

The maximum waiting period for the slave's answer may be configured both for a serial or TCP slave.

This waiting period must be lower than the maximum answer waiting period configured in the Master.

To configure message timeout through the Web Page:

- Select "Modbus" from the menu.

- Enter the Message timeout value desired
- Click on the "Send" button to make the EGW1-MB take the changes.

Message Time Out (250..30000 msec.)

Digital Input/Output's Address (1..255)

Send

From the command console, you must execute the **MSGTOUT** command.

Table 15 - MSGTOUT command

Command	Description
MSGTOUT : (. .)	Changes the maximum waiting period for answer from the slave. It is expressed in milliseconds.

3.2.8.3 Slave Address (Slave Mode)

The field Unit ID of a Modbus/TCP message is conceived to direct multiple slaves to a same IP address. Some old applications presume the existence of an only Slave for each IP address and always send the ID field in 0.

EGW1-MB in Slave Mode can be configured to translate all messages from any Unit ID into a fixed determined address. This option may or may not be enabled, and, also, you may configure the fixed address to which you wish the messages to be translated. Please note that enabling this option means a restriction to an only serial slave. To enable or disable this option, or to change the fixed address from the configuration Web Page:

- Select "Modbus TCP" from the menu
- Enter the fixed Slave address and check the box to enable the option
- Click the "Send" command to make the EGW1-MB take the changes.

From the command console, you may execute the **SLVADDR** command.

Table 16 - SLVADDR command

Command	Description
SLVADDR : (D 1..255)	Enables/Disables or changes the fixed address to which the Mode Slave ID address will be translated. D = Disabled (1..255) = Enabled/Fixed Address

3.2.8.4 Broadcast Address (Slave Mode)

When using Slave mode, you may configure EGW1-MB to translate broadcast messages to an address that may be fixed or not. These parameter will not have effects if the slave's fixed address parameter is enabled.

To configure this option through the configuration Web Page:

- Select "Modbus TCP" from the menu
- Enter the address to convert the broadcast messages to.
- Click the "Send" command to make the EGW1-MB take the changes.

You may configure this parameter through the command console, you must execute the **BROADADDR** command.

Table 17 - BROADADDR command

Command	Description
BROADADDR: (0..255)	Changes the translation address of Broadcast messages in Slave Mode. If it is set in 0, broadcast messages are not translated.

3.2.8.5 Messages Buffer (Slave Mode)

The specificity of the Modbus/TCP defines that the masters must handle one message at a time. Nevertheless, the TCP/IP features make it possible to save the messages to be able to process them one at a time.

EGW1-MB allows you to select what kind of behavior you expect related to this option.

If it is enabled, EGW1-MB will save the messages received while waiting for the answer of an already sent message, once the process of the pending message is finished, EGW1-MB will process the next message.

If the option is disabled, EGW1-MB will save only the last message received. Once the last pending message has been processed, EGW1-MB will process the last message received.

It is recommended to maintain this parameter disabled to prevent excessive queues of messages.

If this occurs, try to lower the answer maximum waiting time.

To enable or disable the Buffer TCP option through the Web page:

- Select "Modbus TCP" from the menu
- Enable or disable TCP Buffering in the combo box.
- Click on the "Send" button so the changes take effect.

You may configure this parameter through the command console by executing the **TCPBUFFER** command.

Table 18 - TCPBUFFER command

Command	Description
TCPBUFFER: (E D)	Enables or disables the option of saving TCP messages received and then executing them in turns. Only for Slave Mode. E = Enable (Saves the messages and processes them in turns). D = Disabled (Saves only the last message received).

3.2.8.6 Inactivity Timeout

When EGW1-MB detects inactivity in the connection sockets, it may close the socket after some inactivity time that can be configured, or keep the socket opened indefinitely.

To change the maximum inactivity timeout through the Web Page:

- Select "Modbus TCP" from the menu
- Enter the Inactivity timeout value.
- Click on the "Send" button so the changes take effect.

From the command console, you can execute the **INACTOUT** command.

Table 19 - INACTOUT command

Command	Description
INACTOUT: (..)	Changes the maximum inactivity timeout allowed to opened sockets (inputs or outputs). If it is configured in 0 seconds, the sockets will be kept opened indefinitely, regardless inactivity.

3.2.9 Inputs/Outputs

EGW1-MB may receive messages from a remote Modbus/TCP Master in Slave Mode or from a Modbus/ASCII-RTU Master in Master Mode, with the purpose to read/write its inputs/outputs. If this option is enabled, EGW1-MB acts as Modbus/TCP slave in Slave Mode or as Modbus/ASCII-RTU slave in Master Mode, when a message arrives to the programmed address.

Apart from enabling this option, you must configure EGW1-MB inputs/outputs slave address.

To enable/disable this option and to change the EGW1-MB slave address through the Web Page:

- Select "Modbus" from the menu.
- Enter the Address and check the box to enable the option.
- Click on the "Send" button so the changes take effect.

From the command console, you can execute the **IOADDR** command.

Table 20 - IOADDR command

Command	Description
IOADDR: (D 1..255)	Enables/Disables – Changes the EGW1-MB slave address to act/read inputs/outputs. D = Disabled 1..255 = EGW1-MB slave address

EGW1-MB inputs have a reference range of 0 to 3 (10001 to 10004 in Modbus).

EGW1-MB outputs have a reference range of 0 to 3 (00001 to 00004 in Modbus).
If the option is enabled, EGW1-MB will act upon its inputs/outputs by executing the following Modbus commands:

1. Read Coil (FC 1) Reads an output status.
2. Read input discretes (FC 2) Reads an input.
3. Write Coil (FC 5) Changes the status of an output.

3.2.10 Statistics

Both, in Slave or Master mode, the EGW1-MB maintains a lists of communication statistics. These are intended for diagnostics of problems.

Statistics differ from in Master mode or in Slave mode.

To read the statistics from the command console you can type the command STATSLIST. At any time you can re-start statistics by typing the STATSCLEAR command.

Table 21 - Statistics

Command	Description
STATSLIST	List statistics
STATSCLEAR	Clear all statistics

Statistics can be read through the Web Page selecting "Statistics" from the menu.

3.2.10.1 Reading Statistics using Modbus commands

If the inputs/outputs option is enabled, statistics can be read as if they where holding registers. In this tables you can see on which address they are mapped.

Each one of them is an integer long word.

▪ Slave Mode

40002-40003 TCP, Requests Count
40004-40005 TCP, Wrong Requests
40006-40007 TCP, Unbuffered Requests
40008-40009 TCP, I/O Requests
40010-40011 TCP, I/O Exceptions
40012-40013 TCP, Serial Requests
40014-40015 TCP, Other Exceptions
40016-40017 TCP, Socket Openings
40018-40019 TCP, Opened Sockets
40020-40021 TCP, Inactivity timeout closes
40022-40023 TCP, Socket waiting Closes
40024-40025 Serial, Valid Responses
40026-40027 Serial, Parity Errors
40028-40029 Serial, CRC/LRC Errors
40030-40031 Serial, Length Errors
40032-40033 Serial, Wrong Unit Responses
40034-40035 Serial, Other Errors
40036-40037 Serial, Responses Timed Out

- **Master Mode**

40002-40003 Serial, Requests Count
40004-40005 Serial, Parity Errors
40006-40007 Serial, CRC/LRC Errors
40008-40009 Serial, Length Errors
40010-40011 Serial, Other Errors
40012-40013 Serial, IO's Requests
40014-40015 Serial, IO's exceptions
40016-40017 Serial, Rejected Broadcasts
40018-40019 Serial, Wrong Unit Requests
40020-40021 Serial, Other exceptions
40022-40023 TCP, Socket Openings
40024-40025 TCP, Failed Socket Openings
40026-40027 TCP, Opened Sockets
40028-40029 TCP, Unexpected Closings
40030-40031 TCP, Inactivity Time Out Closes
40032-40033 TCP, Valid Responses
40034-40035 TCP, Invalid Headers
40036-40037 TCP, Responses Timed Out

To clear the statistics write on Holding Register 40001 a value different to zero.

Appendix A

A. Appendix

A.1. Device Locator Application

The Exemys Device Locator Application Program is intended to use for the basic configuration of any Exemys device over your ethernet network. It allows to search, identify and configure the basic network parameters.

This simple application program is distributed with any Exemys product in the accompanying CD. You can also download the latest version of this program from the Exemys Web Site (www.exemys.com).

The Device Locator application must be running from any PC within the network where the Exemys devices to configure are installed.

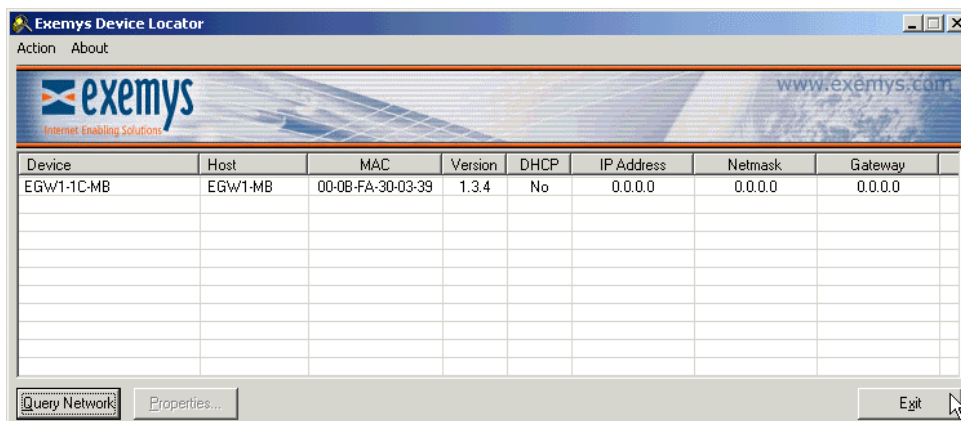

Figure 12 - Exemys Device Locator

When the Device Locator is run for the first time it will search any Exemys device within the network. If there is an Exemys device in the network it will be shown in Device Locator Grid:

- Device: Device name, such as EGW1-MB or KIBe.
- Version: Firmware version it is running in that device.
- MAC Address: Hardware Ethernet Address of the device.
- IP: IP Address configured in the device
- Netmask: Subnet mask configured in the device
- Gateway: Gateway IP Address configured in the device.

- DHCP Lease: if "Yes", then the device network parameters were obtained from a DHCP server.

It is not necessary for the device to be properly configured. If the device is correctly connected and working, it will be found by the Device Locator Application Program.

To refresh the grid, click on the "Query Network" button. This action will make the device Locator to search any Exemys device in the network again.

You can change any of these basic network parameters within the Device Locator program.

To configure any Exemys device founded by the Device Locator:

- Select the device in the grid and click on the "Properties" button, or open the "Actions" menu and select the "Properties" command. You will see the Properties dialog box.
- All Exemys devices provide a Remote Configuration Password. This password is used for the Web configuration page and remote command Console in the device. Enter this password in the "Enter current password" box if the device has a configured password.
- You can type an IP Address, Netmask and Gateway IP Address or you can click on the "Use DHCP" check box to make the device search a DHCP Server.
- Click on the "Ok" button so the Device Locator sends this information to the device.
- If the password is not correct, the Device Locator will show a "Error Response from MAC Address XX-XX-XX-XX-XX-XX". The device will not respond any message sent by the Device Locator software within the first 5 seconds after an incorrect password configuration attempt. This is to avoid any brute force method to change the network parameters of the device.
- If the device does not respond, the Device Locator will show a "No Response from Device" message. Make sure the device is turned on and connected to the ethernet network.
- The Exemys device will reset so the changes in the configuration take effect.
- Click on the "Close" button to close the Properties dialog box.
- After a few seconds the device being reset will answer again to the requests of the Device Locator software. Click on the "Query network" button to refresh the grid and make sure the parameters were changed.

A.2. Indicator Leds Codes

EGW1-MB features two indicator LEDs: green and yellow.

The Yellow and it shows the general working order of the equipment.

The green led indicates data incoming status.

Table 22 - Indicator Leds Codes

Yellow Led	Green Led	Description
It flashes alternately with Green Led	It flashes alternately with the Yellow Led	Critical failure.
It is steady on		EGW1-MB is searching for a DHCP server on the network.
It is ½ second on and ½ second off.		EGW1-MB is waiting for an IP address configuration ping or the CFG command to be entered.
It blinks like a beacon, 90% of a second off and the remaining 10% on.		EGW1-MB has an IP address and a carrier (link) on the connection. This is the normal operation status.
It is 90% of a second on and the remaining 10% off		It has no IP address and it could not find a DHCP server. It will search the DHCP server at 60-second intervals.
It blinks very fast.		Absence of carrier on the link.
	It is steady on and it turns off for shorts periods of time	EGW1-MB has detected Data in one of the connections

A.3. Mounting

The device should be mounted on a DIN rail (as shown in figure 15), to allow it to place on electric panel, control panel cabinets, and interconnection cases.

Make the upper side of the device fit the DIN rail (A) and then push gently until you hear a Click! (B).

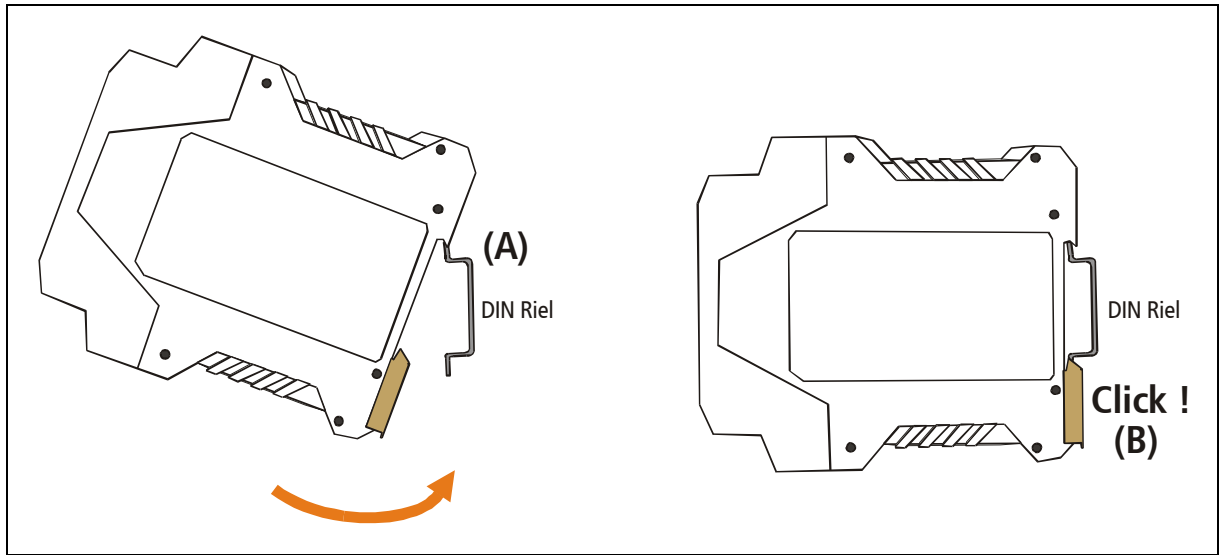

Figure 13 - Assembly of the device on DIN rail

To disassemble the device of the rail DIN (figure 16), pull down the metallic clip and then remove it (C).

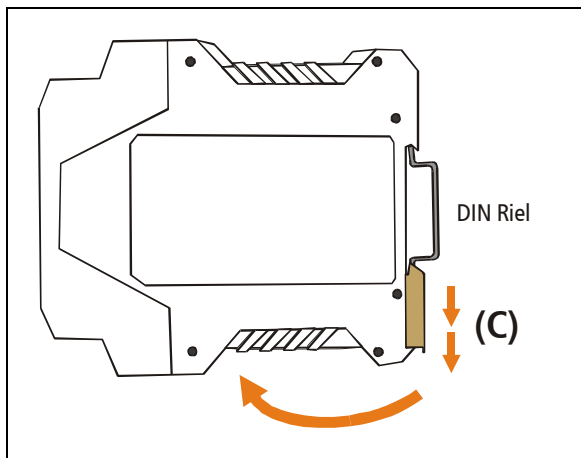

Figure 14 - Disassembling of the device

A.4. Technical Specifications

• Network Protocols:	TCP / IP, UDP, TELNET, HTTP, DHCP, ICMP, ARP, MODBUS TCP.
• Network Interface:	Ethernet 10 BaseT, RJ45 connector.
• Serial Protocols:	MODBUS ASCII, MODBUS RTU.
• Serial Interface:	RS232/485/422/ serial ports in pluggable terminal blocks.
• Devices Supported:	Any RS232/485/422 Serial Port device using Modbus Protocols requiring Ethernet access.
• Inputs/Outputs:	<u>Inputs:</u> NPN Sinking, 3.5 to 28 Volts DC, 1 to 11mA max. <u>Outputs:</u> NPN Sourcing, high drive, open collector, 3 to 45 Volts DC, 130 mA max. per channel. Industrial pluggable terminal blocks.
• Management:	HTTP Server, password protected. TELNET Console, password protected. Serial RS232 Console.
• System Firmware:	Downloadable via programming cable (optional).
• Indicators:	Status Led, Data/Link Led.
• Dimension / Weight:	4.49 x 3.94 x 0.89 in. (HxWxL). (114 x 100 x 22.5 mm). 0.31 Lbs (0.140 Kg).
• Power supply:	Must be from a Class 2 or LPS source. 9 to 26 Volts AC. 9 to 30 Volts DC. 200 mA max.
• Environmental:	Operating temperature: 23 to 149 °F (-5 to 65 °C). Storage temperature: -40 to 167 °F (-40 to 75 °C).
• Optional Accessories:	Programming cable.
• Guarantee / Support:	1-year guarantee. Technical support included.